

nVent Hoffman Purge/Pressurization Manual for Models PLCF1YZ PLCB1YZ

This manual covers Type Y/Z - Purge with Leakage Compensation

CONTENTS:

- 1. Specification Sheet – LC Y/Z – Purge/Pressurization Units**
- 2. Application Suitability**
- 3. Installation, Operation and Maintenance for LC Unit**
 - Section 0. Description and Principle of Operation**
 - Section 1. Installation of the Unit**
 - Section 2. Operation of the Unit**
 - Section 3. Maintenance of the Unit**
 - Section 4. Fault Finding - LC Unit**
- 4. Drawings**
- 5. Certificates**

1. Specification Sheet – nVent Hoffman Purge/Pressurization Units

Model No. (Example): P LC B 1 YZ (Note: Not all codes are applicable)

Purge Unit Type ←

P = Purge/Pressurization Unit

Purging Method ←

LC = Leakage Compensation

Mounting Style ←

B = Back Plate (Top/Side Mount) 316L
Stainless Steel (NROB finish)
F = Flush Mount (Side/Front Mount) 316L
Stainless Steel (NROB finish)

Size ←

1 = Purge flow rate 8 scfm, 225 NI / min

Approvals / Certifications

Y = Z =

Europe
EN 60079-0, EN 60079-2,
EN 61241-0, EN 61241-4
Sira 14ATEX1045X

2813  II 2 (2) G D
Ex [py] II T6 Gb
Ex [p] IIIC T85°C Db
Tamb -20°C +55°C

2813  II 3 (2) G D
Ex [pz Gc] IIC T6 Gb
Ex [p Dc] IIIC T85°C
Tamb -20°C +55°C

IEC
IEC 60079-0, IEC 60079-2,
IEC 61241-4
IECEX SIR14.0019X

Ex [py] II T6 Gb
Ex [p] IIIC T85°C Db
Tamb -20°C +55°C

Ex [pz Gc] IIC T6 Gb
Ex [p Dc] IIIC T85°C
Tamb -20°C +55°C

USA / Canada NFPA 496
UL E466718
Class I Div 1
Groups A, B, C & D

Class I Div 2
Groups A, B, C & D

For limitations and conditions of use refer to the applicable certificate at the back of this manual.

Supply Pressure: 60 psi / 0.4MPa / 4 barg must be regulated at inlet.
Maximum supply pressure 115 psi / 0.8MPa / 8 barg. Compressed Air / Nitrogen

Flow & Pressure Sensors

"Low Pressure Sensor": 0.2 "WC / 50 Pa (0.5 mbarg)
"Flow Sensor": 1.38 "WC / 350 Pa (3.5 mbarg)

Leakage Compensation: Variable up to 2 scfm (60 NI/min) to compensate for Enclosure Leakage

Relief Valve

Opening Pressure: 4" WC / 1 kPa (10 mbarg)
Material: 316L Stainless Steel, Spark Arrestor: Stainless Steel mesh, Neoprene Gasket

Action on "Loss of Pressure": ALARM ONLY

Alarm Switch (Signals)

Zone 2 / Division 2 "Alarm": Dry, VFC, SPSTN/O Contact NI – Ex nA Non-incendive Circuits V _{max} < 254 V ac rms I _{max} < 1 A	Hermetically Sealed Switch Ex m IIC T4 Gc V _{max} = 254 Vac rms I _{max} 0.7 A
Zone 1 or 2 / Division 1 or 2 IS – Ex i circuits U _{max} = 30 Vdc I _{max} 0.7 A	

2. Application Suitability

nVent Hoffman Purge/Pressurization Units are certified for use in Hazardous Areas, where the Hazardous Area is non-mining (i.e. above ground) and the hazard is caused by flammable gasses, vapors or dust.

Z-Purge Units may be used in IECEx, ATEX Zone 2(22) - Category 3 and NEC 500 Class I, Div 2.

Y-Purge Units may be used in IECEx, ATEX Zone 1(21) - Category 2 and NEC 500 Class I, Div 1.

nVent Hoffman Purge/Pressurization Units may be used for hazards of any gas group. However, apparatus associated with the nVent Hoffman Purge/Pressurization Unit, such as Non-Incendive, Intrinsically Safe signaling circuits and flameproof enclosures containing switching devices may be limited in their gas group. The certification documentation supplied with any such devices must be checked to ensure their suitability.

This unit is designed for use primarily with compressed air. Where other inert compressed gasses are used (Nitrogen, for example) the User must take suitable precautions so that the buildup of the inert gas does not present a hazard to health. Consult the Control of Substances Hazardous to Health (COSHH) data sheet for the gas used. Where a risk of asphyxiation exists, a warning label must be fitted to the Pressurized Enclosure.

The following materials are used in the construction of nVent Hoffman Purge/Pressurization Units. If substances that will adversely affect any of these materials are present in the surrounding environment, please consult nVent Hoffman for further guidance.

Materials of construction:

Stainless Steel	Aluminum	Acrylic
Mild (carbon) Steel	Nylon	Silicone Rubber
Brass	Polyurethane	Neoprene

3. Installation, Operation and Maintenance for LC Units

This nVent Hoffman Purge/Pressurization Unit is designed for use under normal industrial conditions of ambient temperature, humidity and vibration. Please consult nVent Hoffman before installing this equipment in conditions that may cause stresses beyond normal industrial conditions.

The nVent Hoffman Purge/Pressurization Unit shall be installed and operated in accordance with relevant standards, such as IEC / EN 60079-14, NEC 500, NFPA 496 and any local codes of practice that are in force.

For IEC / ATEX applications, references to the NFPA 496 within this instruction manual, should be replaced by the equivalent clause in IEC / EN 60079-2.

For IEC / ATEX applications, the "Example calculations:" in section 1.1.4 within this instruction manual, should read:

If the PE external dimensions indicate a volume of 0.5 m³ (17.7 Ft³) then,

$$\frac{0.5 \text{ m}^3 \text{ (or } 17.7 \text{ ft}^3\text{) enclosure volume} \times 5 \text{ volume changes}}{0.225 \text{ m}^3/\text{min} \text{ (or } 8 \text{ scfm) purge flow rate}} = 12 \text{ minutes purge time}$$

Installation, Operation and Maintenance Manual for nVent Hoffman Purge/Pressurization Unit Leakage Compensation (Model LC) conforming to NFPA 496

IMPORTANT NOTE It is essential, to ensure conformity with the standard, that the User of the unit observes the following instructions.

Please refer to the latest standard for detailed requirements and definitions.

Contents:

Section 0 Description and Principle of Operation
Section 1 Installation of the Unit
Section 2 Operation of the Unit

Section 3 Maintenance of the Unit
Section 4 Fault Finding
Section 5 Annex (if applicable)

Section 0 Description and Principle of Operation

All nVent Hoffman Purge/Pressurization Unit® pressurization units provide:

a) a method of pressurizing a Pressurized Enclosure (PE) while at the same time compensating for any leakage, together with

b) a method of purging the enclosure, before power is turned on, to remove any flammable gas that may have entered the enclosure while it was not pressurized.

Type **Leakage Compensation (LC)** unit is comprised of the following two major parts:

- A **Control Unit (CU)** containing as a minimum, for "Y/Z" Pressurization, a Leakage Compensation Valve (LCV), Minimum Pressure and Purge Flow sensing devices, and a "Pressurized"/"Alarm" indicator. The CU supplies a 'Pressurized' signal showing whether the PE pressure is satisfactory or not.

- A **Relief Valve (RLV)**, fitted to the PE, to provide a means of limiting the maximum pressure experienced by the PE during operation. All RLVs incorporate a Spark Arrestor to

prevent sparks being ejected from the PE through the RLV aperture.

0.1 "Leakage Compensation" Units, Model LC

A Leakage Compensation (LC) Unit is intended to have minimal flow after the initial purge time. The PE is built as leak tight as possible and the LC unit merely tops up for any enclosure leakage. The unit provides an initial high flow of purging air that leaves the PE through the Relief Valve. After the initial purging has been completed the Control Unit changes over to Leakage Compensation mode and the Relief Valve closes. The only flow thereafter is the flow through the "Leakage Compensation Valve" (LCV) which is adjusted so that the flow is enough to compensate for any leakage from the PE. The Purging Flow rate is monitored by a separate "Purge Flow Sensor" located in the CU, which detects the differential pressure across the purge flow orifice located directly before the RLV. The Purge Flow Sensor is set to operate when the desired differential pressure is exceeded. The output from the Flow Sensor is indicated on the CU.

Section 1 Installation of the Unit

The installation of the nVent Hoffman Purge/Pressurization Unit, the protective gas supply, any alarm device should be in accordance with the requirements of NFPA 496.

The electrical installation associated with the nVent Hoffman Purge/Pressurization Unit shall conform to the local codes and the relevant clauses of NFPA 496.

1.1 Installation of the nVent Hoffman LC Unit

1.1.1 The nVent Hoffman Purge/Pressurization Unit should be installed either directly on or as close as possible to the Pressurized Enclosure (PE). It should be installed so that the unit indicators may be readily observed.

1.1.2 All parts of any unit carry a common serial number. If installing more than one unit, ensure that this commonality is maintained on each installation.

1.1.3 Any tubing, conduit and fittings used to connect to the PE should be metallic, or, if non-metallic, conform to the local codes for flammability ratings. No valve may be fitted in any tube connecting the nVent Hoffman Purge/Pressurization Unit to the PE.

1.1.4 The User or manufacturer of the PE shall determine the volume of the PE, the necessary purging volume, and the time to be allowed for purging, using the chosen nVent Hoffman Purge/Pressurization Unit purging flow rate. It is the

User's responsibility to verify or enter this data on the PE and/or unit nameplate. Ask nVent Hoffman if in doubt.

Example calculations:

a) If the PE external dimensions give a volume of 20 cubic feet, and it is NOT a motor, multiply the volume by four to get the Purging Volume i.e. 80 cubic feet. Divide the Purging Volume by the purge rate e.g. 32 cubic feet per minute, and round up to the next even minute above, i.e. Purging time would be 4 minutes.

b) If the PE is a motor, multiply the internal free volume by ten to get the Purging Volume. For the example above, purging time would be 8 minutes.

1.1.5 If the PE contains an internal source of release of flammable gas or vapor, the procedures for assessment of the release as given in NFPA 496 shall be observed. The User must verify that the specification of the nVent Hoffman Purge/Pressurization Unit e.g. pressures, type of protective gas are correct for the specific application.

1.1.6 More than one PE can be protected by a single unit. If PEs are connected and purged in "series" e.g. "Daisy Chained", the Outlet Orifice must be fitted on the last enclosure with the Purge Inlet to the first enclosure. The bore and length of the tube or conduit used to interconnect the enclosures is critical and will determine the maximum

pressure experienced by the first enclosure in the series. Advice on sizing can be obtained from nVent Hoffman. The test pressure for all the enclosures should be 3 times the pressure inside the first enclosure when purging is taking place. If PE's are to be connected in parallel each enclosure must have its own outlet Relief Valve, Purge Flow Sensor and Pressure Sensor.

1.2 Quality and Installation of the Pressurizing Air or Inert Gas Supply

1.2.1 The source of the compressed air must be in a non-classified area. Inert gas may be used as an alternative to compressed air.

1.2.2 Unless a supply shut-off valve has been specially fitted within the unit, a valve with the same, or larger, thread size as the Control Unit inlet fitting shall be fitted externally. In addition, for "Y/Z" Pressurization units, a suitable indicator shall be provided.

1.2.3 The tubing and fittings used must conform to 1.1.3 above.

1.3 Provision and Installation of Alarm Devices

nVent Hoffman Purge/Pressurization Units have a Minimum Pressure Sensor set to a pressure of at least 0.1" WC (0.25 mbar). When the PE pressure is above this set point the Sensor produces a positive "Pressurized" signal. This is displayed on a Red/Green indicator. This signal is used to operate an electrical contact for a remote "Alarm", suitable for an Intrinsically Safe circuits, in accordance with nVent Hoffman drawing 89107938 (or for a Non-Incendive)

When the enclosure pressure falls below the set point of the Sensor the "Pressurized" signal is removed, i.e. the absence of the signal indicates an "Alarm" ("Pressure Failure") condition. The User must make use of this external alarm facility in accordance with NFPA 496 requirements, if the unit "Alarm" indicator is not located in a place where it can be readily observed.

The Alarm switch will reset, and its contacts can be used to operate a remote electrical alarm.

nVent Hoffman application tip: Exception: For a "Z Purge" unit fitted in a Division 2 area, a non-classified switch inside the PE can be used to operate a remote Alarm provided its electrical supply comes from within the PE

(i.e. NOT PROVIDING DRY CONTACTS). When the PE power is switched off there is no need for an alarm.

1.4 Power Supplies and their Isolation

1.4.1 All power entering the PE shall be provided with a means of isolation. This requirement also applies to any external power sources that are connected to "dry contacts" or "volt-free contacts" within the PE. Exception: Power to Intrinsically Safe, or other apparatus, which is already suitable for the location, need not be isolated by the nVent Hoffman Purge/Pressurization Unit. When utilizing "Y/Z" Pressurization the power may be controlled manually by the User by the use of local isolating switch.

1.4.3 The Power (cut-off) Switch must be approved for the location or located in a non-classified area.

1.4.4 No valves are permitted between the Power Switch and the nVent Hoffman Purge/Pressurization unit.

1.5 Marking

1.5.1 The nVent Hoffman Purge/Pressurization Unit carries a nameplate and a specification sheet, which give specific data such as serial and models numbers, Pressure Sensor settings, flow rates and purge time.

1.5.2 Other marking, for the PE, required by the standard includes:

"WARNING - PRESSURIZED ENCLOSURE

This enclosure shall not be opened unless the area is known to be free of flammable materials or unless all devices within have been de-energized" "Power shall not be restored after the enclosure has been opened until the enclosure has been purged for ____ minutes at a flow rate of ____."

nVent Hoffman note: It is understood that NFPA 496 requires to de-energize of all devices that are not suitable for the hazard, e.g. devices that are not Explosionproof or Intrinsically Safe. For example, an explosionproof anti-condensation heater would not have to be de-energized.

1.5.3 If Inert Gas is used as the Protective Gas and a risk of asphyxiation exists, a suitable warning plate should be fitted to the PE.

Section 2 Operation of the Unit

2.1 Initial Commissioning

2.1.1 Check that the unit has been installed in accordance with Section 1 of this manual.

2.1.2 Disconnect the supply pipe from the inlet to the Control Unit and blow clean air through for at least 5 seconds per foot of length (15 sec / meter) to remove any debris, oil and condensation.

2.1.3 Connect a temporary pressure gauge or liquid manometer to the PE or Control Unit "Pressure Test Point", [on the LP Sensor, by the removal of the Red plug - 5/32" (4mm) OD nylon tube].

2.2 Commissioning Leakage Compensation (LC) "Y/Z" Units.

On LC "Y/Z" Purge units, proceed as follows:

2.2.1 Open the supply shutoff valve.

2.2.2 Adjust the Leakage Compensation Valve (LCV) so that the enclosure pressure rises to the point where the "Pressurized" indicator turns green.

2.2.3 Continue to raise the PE pressure until the Relief Valve (RLV) opens. Check that the RLV opens at or below the figure specified in the documentation. Repeat the test several times.

2.2.4 Lower the PE pressure until the "Pressurized" indicator turns Red. Check that the indicator turns Red at or above the pressure specified in the documentation. Check the external alarm contacts.

2.2.5 Open the LCV again and set the PE pressure to a level around 50% of the RLV operating pressures. This "working" pressure is not critical. The "Pressurized" indicator should be Green.

2.2.6 Turn the Purge Control Valve "On". This will start the High Purge Flow and the "Purging" indicator should turn Yellow. If the "Purging" indicator remains Black, the flow through the outlet valve is below the minimum for which the Flow Sensor has been calibrated. Check the air supply pressure at the inlet to the Control Unit while purging is taking place. It must be above the minimum specified. If the supply pressure is correct and the "Purging" indicator does not turn Yellow, there is too much leakage from the Pressurized Enclosure.

"Purging" does not start until the indicator turns Yellow

2.2.7 On LC "Z" Purge units the purge timing function is performed by the User. When the "Purging" indicator turns Yellow the Purge Flow is above the minimum required and the purge time can start. The User must ensure that the time delay between the indicator turning Yellow and the application of power to the PE is not less than the minimum time required to purge the PE as shown on the PE or Purge/Pressurization Unit nameplate.

Never turn on the power without purging first unless you have proved that the interior of the PE is gas free and checked that the "Pressurized" indicator is green!

2.2.8 After the purge time is completed the Purging Valve should be turned "Off". The High Purge Flow will cease and the air flow into the enclosure will then be controlled once again by the Leakage Compensation Valve (LCV), it should now be re-adjusted if necessary. The RLV should be closed and the enclosure pressure around 50% of the RLV opening pressure. If this is not so there are three possible situations:

a) Air continues to come out through the Spark Arrestor, after High Purge has been turned "Off", in considerable quantity. The LCV is too far open, and the air flow is holding

the RLV open continuously. Close the LCV slowly observing the manometer or gauge (see item 2.1.3 above). The PE pressure will start to fall as the flow decreases but eventually the RLV will close and the pressure rise again. At this point the Relief Valve will start to open intermittently as the PE pressure rises to the point where it exceeds the RLV opening pressure. When the RLV opens the pressure will fall quickly to the point where the RLV recloses and the enclosure pressure starts to rise again. This is entirely normal for this type of RLV. Proceed now to b) below:

b) If the Relief Valve is opening intermittently the LCV is slightly too far open. Observe the manometer or gauge. When the RLV opens the enclosure, pressure falls quickly to the point where the RLV re-closes and the enclosure pressure starts to rise again. This is entirely normal for this type of RLV and shows that it is working correctly.

Continue to close the LCV until the cycling stops and the enclosure pressure starts to fall. Carefully adjust the LCV until the PE pressure is approximately 50% of the RLV opening pressure and stable. This pressure may be around 2" WC (5 mbar) and will be the "normal working pressure".

c) If, at the end of purging, the PE pressure falls below the Minimum Pressure Sensor setting the LCV is not open far enough. The LCV should be opened until the PE pressure is around the normal working pressure.

2.2.10 Type "Y/Z" purge units do not control the enclosure power. It is the responsibility of the User to switch off the power whenever the enclosure pressure falls below the minimum permitted i.e. when the "Pressurized" indicator turns Red.

2.4 Normal Operation

2.4.1 Turn the air supply valve On or Off to start or stop the unit,

2.4.2 The User must close the Power Switch only after the enclosure has been pressurized and purged sufficiently to ensure that the interior of the enclosure is gas free. It is the User's responsibility to shut off the power, as soon as possible after a pressure failure.

Section 3 Maintenance of the Unit

The maintenance recommended for the unit consists of the following, supplemented by any additional local requirements imposed by the authority having jurisdiction.

3.1 Initial Maintenance

nVent Hoffman recommends that the commissioning test be repeated at least every six months. They include checking the opening pressure of the Relief Valve, setting of the Minimum Pressure Sensor, and the "Normal Working Pressure" of the enclosure. In addition, the following checks are also recommended at that time:

- Check the RLV and any other Spark Arrestors. Remove any debris or corrosion or replace the Spark Arrestor with a spare.

- Check the condition of the air supply filter element. Clean or replace it as necessary.

3.2 Routine Maintenance

At least every two years, the following additional checks are recommended:

- Apparatus is suitable for the Hazardous Location
- There are no unauthorized modifications
- The source of air is uncontaminated
- The interlocks and alarms function correctly
- Approval labels are legible and undamaged
- Adequate spares are carried
- The action on pressure failure is correct

Section 4 Fault Finding – LC Units

4.1 General

If the unit does not behave in the manner described above, there is a fault. Some of the more likely faults are dealt with below. If a cure cannot be effected by following the procedure shown below please call nVent Hoffman or your supplier for further assistance. The unit has been designed for ease of fault finding and many of the components fitted are plug-in or sub-base mounted. Check components by substitution only after establishing that such action is necessary. If the unit is less than 12 months old, parts under warranty should be returned to nVent Hoffman for investigation, with a full report of the fault and the unit Serial number. NOTE: As with any pneumatic unit the greatest enemies are water, oil and debris in the air supply. For this reason, a dust and water filter should always be fitted. But debris can enter from other sources and it is vital therefore that the procedure described in Section 2 is carried out before using the unit for the first time or following any disconnection of the pipework. Failure to perform this work may cause damage, which will not be covered under warranty.

Fault Finding NOTE: Before making the following checks verify that the main supply pressure is between 60 and 115 psi (4-8 bar) at the Control Unit.

4.2 Minimum Pressure Alarm is ON Continuously (“Pressurized” Indicator is Red)

Possible cause 1: The Pressurized Enclosure (PE) pressure is too low. Try increasing the setting of the Leakage Compensation Valve (LCV) to raise the pressure in the PE. This is accomplished by turning the LCV in a counterclockwise direction.

Possible cause 2: Enclosure fault?

- Is the ACTUAL PE pressure below the setting of the Minimum Pressure Sensor? Check it with a manometer or gauge.
- Is there debris stuck on the face of the Relief Valve (RLV) disk, perhaps held there because of the magnetic material?
- Has the PE door been closed, and all conduit/cable glands sealed?
- Is the PE leaking too much?
- Has the pressure sensing tube been damaged?

Possible cause 3: unit fault?

If checks above reveal that the PE is correct, the fault probably lies in the Control Unit. The basic operation of the Minimum Pressure Sensor can be checked by unscrewing the 2.4” (60mm) diameter diaphragm and, by using a finger, block the threaded hole in the top of the valve module. The valve should operate, and the indicator should turn Green. If this works correctly and the enclosure pressure is above the setting of the Minimum Pressure Sensor it is likely that the Pressure Sensor diaphragm needs re-calibrating or replacing. (See 4.6)

4.3 Relief Valve Opens (Continuously or Intermittently)

Possible cause 1: The PE pressure is too high.

The Leakage Compensation Valve (LCV) is too far open. Adjust the LCV as described in Section 2 above.

Possible cause 2: Debris on the RLV disk allowing air to leak from the valve. Remove the RLV cover and clean the valve disk. The disk and spring may be removed from the RLV without affecting the calibration.

4.4 “Purging” Indicator Will Not Turn Yellow During Purging

Possible cause 1: Insufficient purging Flow due to inadequate air supply pressure. Check the air supply pressure at the inlet to the CU when flow is taking place. Excessive pressure drop in the supply pipe is a very common cause of this problem. The supply pipe must be at least as big as the CU inlet fitting, i.e. at least ½” NB (12 mm).

Possible cause 2: Excessive Pressurized Enclosure (PE) leakage. Check around the PE when flow is taking place. Any significant leakage must be cured. Has a Leakage Test been done? The total leakage should not exceed 10% of the Purge Flow Sensor setting. Check for leakage down the conduit through unsealed stopping boxes.

Possible cause 3: PE not strong enough. Repeat the PE pressure test. It is recommended that the PE is tested to three times the Relief Valve opening pressure e.g. 12” WC (30 mbar) for units with default settings.

Possible cause 4: The tubing from the RLV Flow Sensing point to the Purge Flow Sensor is not air-tight e.g. fitting nuts not tightened or tube damaged. Check and repair as necessary.

Possible cause 5: The Purge Flow Sensor is not operating correctly or out of calibration. The basic operation of the Purge Flow Sensor can be checked by unscrewing the 2.4” (60 mm) diameter diaphragm and by using a finger, block the threaded hole in the top of the valve module. The valve should operate, and the indicator turn Yellow. If this works correctly and the flow through the Relief Valve is above the minimum required WITH THE RELIEF VALVE COVER FIRMLY SECURED IN PLACE, the Sensor diaphragm needs re-calibrating or replacing.

4.6 Pressure Sensor Calibration

If it is decided that the Minimum Pressure Sensor or Purge Flow Sensor needs re-calibrating it can either be returned to nVent Hoffman for this service or it can be done by the User as follows:

Disconnect the pressure sensing pipe from the top of the diaphragm. (It is a “push-in” quick release fitting; firmly push inwards the collar surrounding the pipe where it enters the fitting, and then pull the pipe outwards while maintaining the pressure on the collar). Unscrew the 2.4” (60 mm) diameter diaphragm housing from the top of the Sensor. Invert it and note the brass adjusting screw in the center. Turning the screw inwards (clockwise) will lower the setting. It is likely that the screw will be very stiff due to the locking sealant. If the screw cannot be moved the application of gentle heat in the area of the brass screw can often help. DO NOT OVERHEAT!

4.7 Filter Cleaning

If the filter element needs cleaning the transparent bowl can be unscrewed and removed. The filter element also unscrews and can then be cleaned in soapy water. Do not use solvents on any part of the filter assembly.

It is sometime easier, if the bowl is very tight, to remove the filter by undoing the fitting that holds the filter into the Control Unit.

Quick Installation Guide – PLCB1YZ

1. With aid of supplied mounting template, cut mounting holes into enclosure. Ensure that Control Unit and Relief Valve are diagonally opposed.
2. Fix Control Unit to enclosure
3. Fix Relief Valve to enclosure
4. Connect Control Unit (Purge Flow Switch) and Relief Valve with 6mm OD, Nylon tubing
5. Connect output (dry contact alarm) as required
6. Connect isolated air supply to Control Unit
7. Ensure enclosure door is closed, fully latched and free of leaks
8. Turn on 60 PSIG (4 bar) air supply (115 PSIG/8 bar max)
9. Slowly increase Leakage Compensation Valve until Alarm Indicator turns from RED to GREEN
10. Turn Purge Control Valve ON and ensure Purge Indicator turns from BLACK to YELLOW
11. After Purge time has been completed turn Purge Control Valve OFF
12. Power can now be applied to the enclosure
13. Refer to manual for assistance

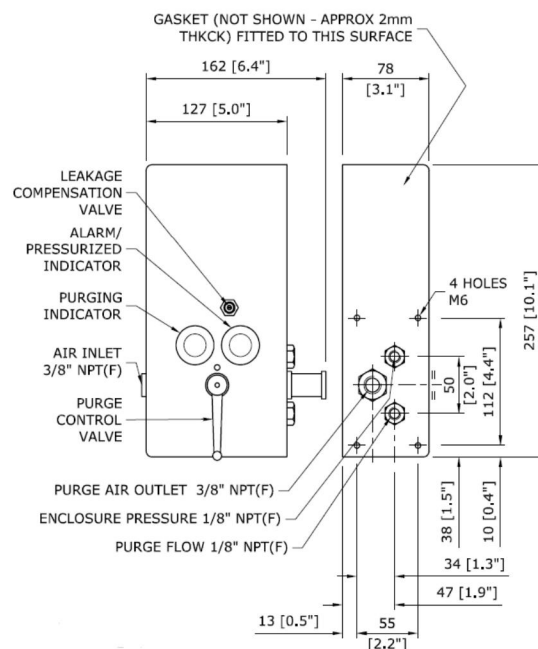
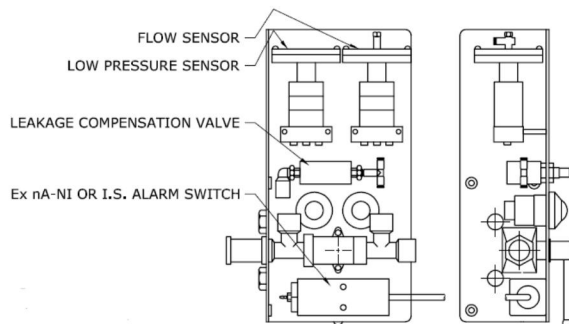
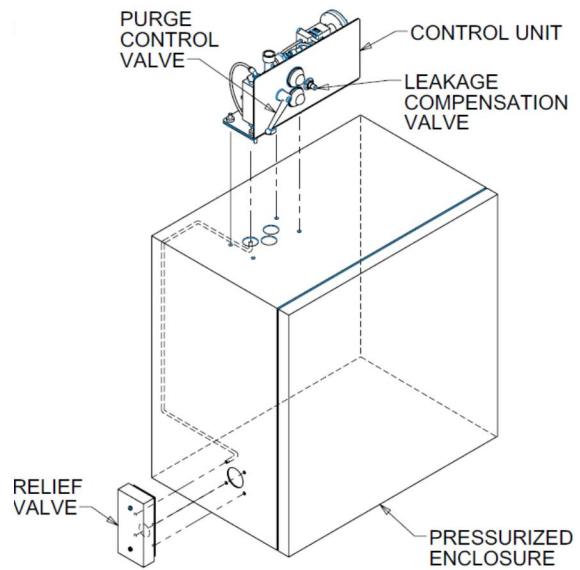

Quick Installation Guide – PLCF1YZ

1. With aid of supplied mounting template, cut mounting holes into enclosure. Ensure that Control Unit and Relief Valve are diagonally opposed.
2. Fix Control Unit to enclosure
3. Fix Relief Valve to enclosure
4. Connect Control Unit (Flow Sensor) and Relief Valve with 6mm OD, Nylon tubing
5. Connect output (dry contact alarm) as required
6. Connect isolated air supply to Control Unit
7. Ensure enclosure door is closed, fully latched and free of leaks
8. Turn on 60 PSIG (4 bar) air supply (115 PSIG/8 bar max)
9. Slowly increase Leakage Compensation Valve until Alarm Indicator turns from RED to GREEN
10. Turn Purge Control Valve ON and ensure Purge Indicator turns from BLACK to YELLOW
11. After Purge time has been completed turn Purge Control Valve OFF
12. Power can now be applied to the enclosure
13. Refer to manual for assistance

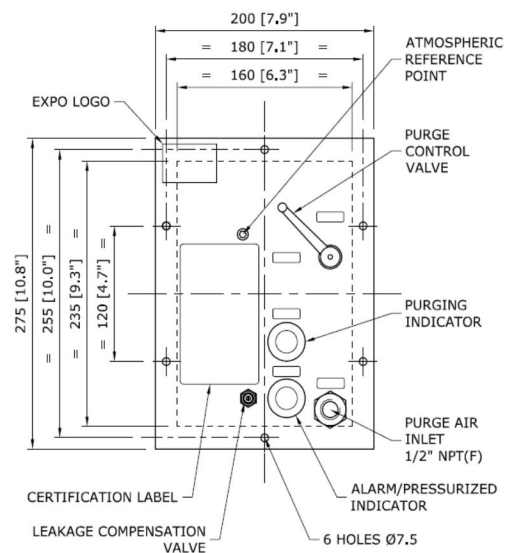
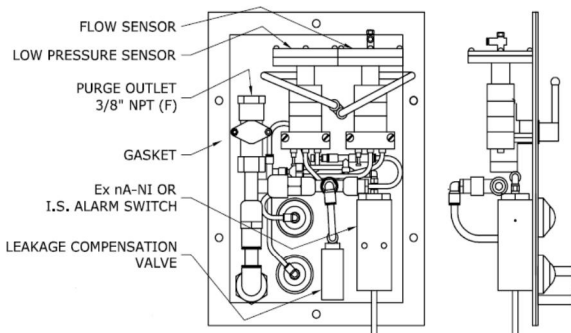
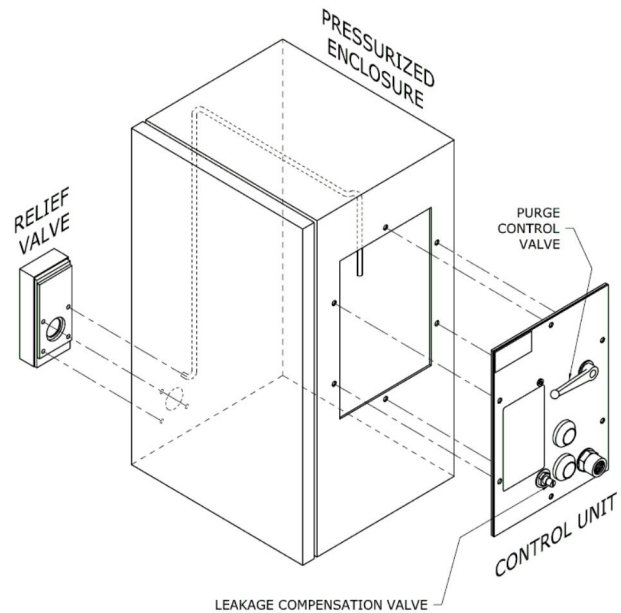

Relief Valve Drawing

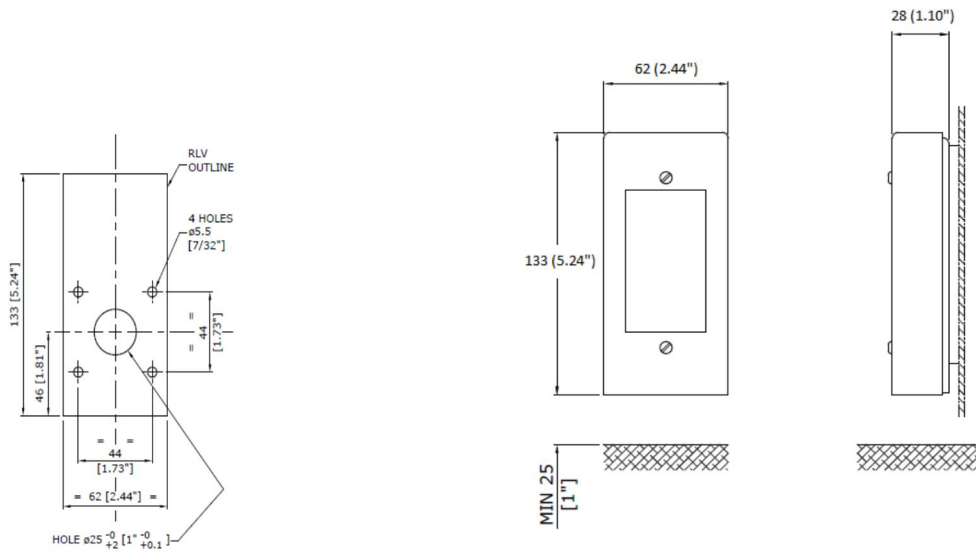

Relief Valve Cutout

Relief Valve Location

Schematic for both PLCB1YZ and PLCF1YZ

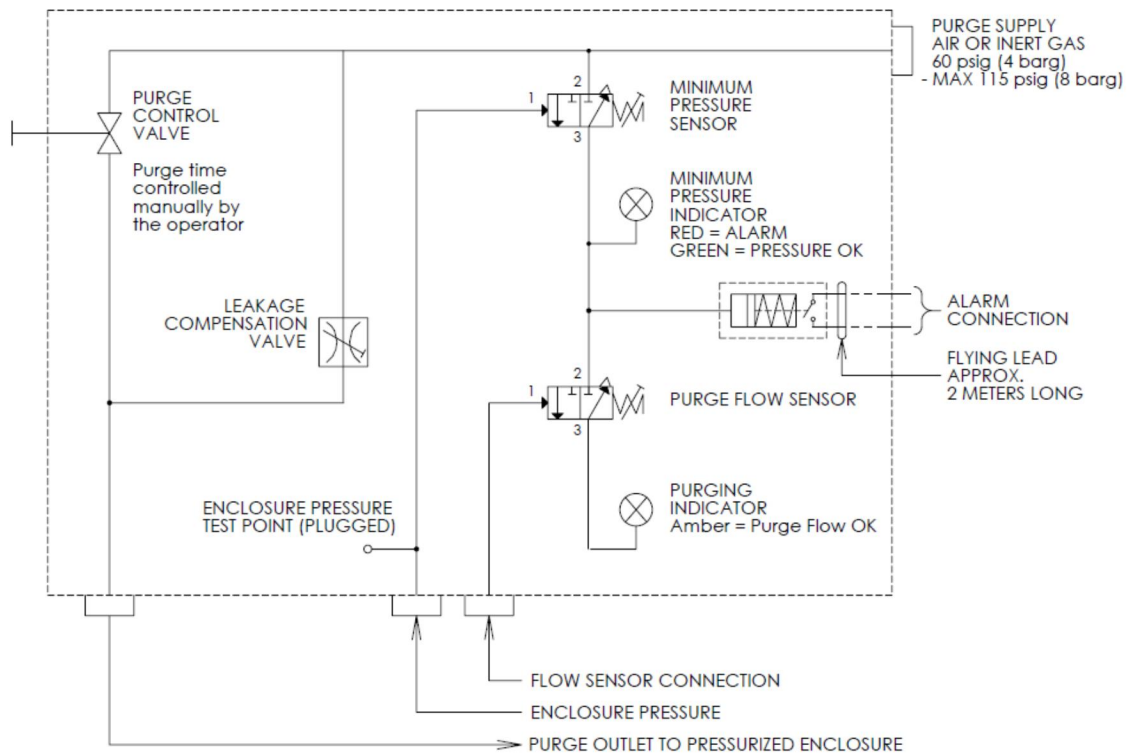
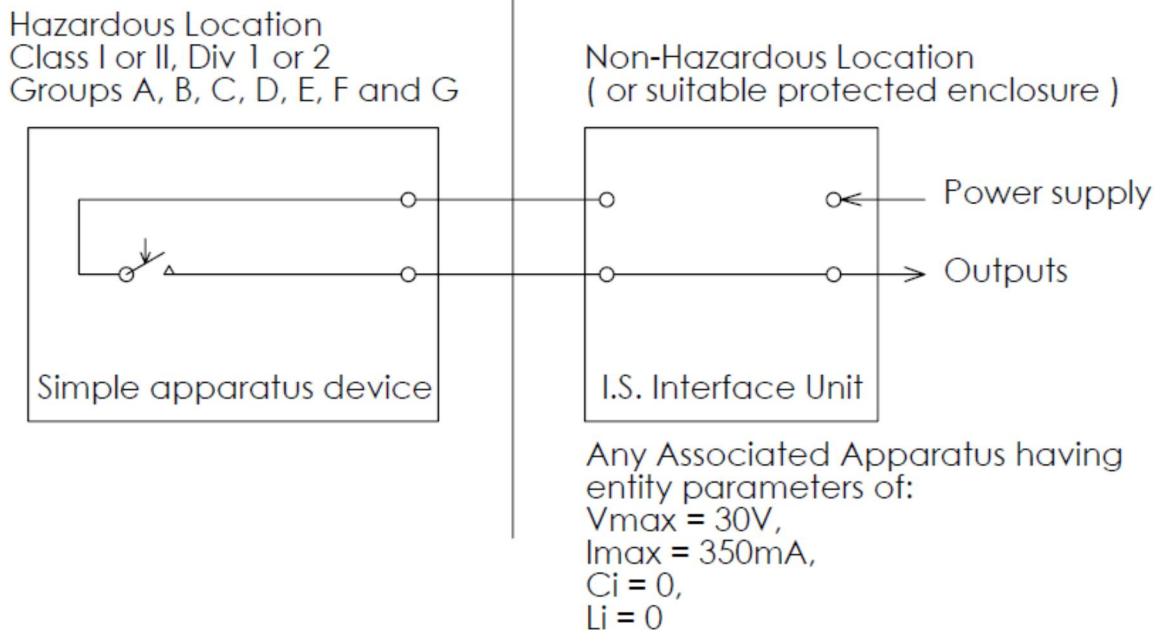

Fig 1 Single channel interface circuit
e.g. "Y" or "Z" Pressurization Alarm circuit



Alarm Switch (Signals)

Zone 2 /Division 2
"Alarm": Dry, VFC, SPSTN/O Contact
NI – Ex nA Non-incendive Circuits
 $V_{max} < 254$ V ac rms
 $I_{max} < 1$ A

Hermetically Sealed Switch
Ex m IIC T4 Gc
 $V_{max} = 254$ Vac rms
 $I_{max} 0.7$ A

Zone 1 or 2 / Division 1 or 2
IS – Ex i circuits
 $U_{max} = 30$ Vdc
 $I_{max} 0.7$ A

Notes for Fig 1 Single channel interface circuit

- 1 Electrical equipment connected to associated apparatus should not use or generate more than 250 volts
- 2 Installation shall be in accordance with the manufacturer's instructions and Article 504 of the NEC(ANSI/NFPA 70)
- 3 For guidance on Installation see ANSI/ISA RP12.6, (Installation of IS Instrument Systems in Class I Hazardous Locations)
- 4 V_{oc} or V_t of associated apparatus is less than V_{max} I_{sc} or I_t of associated apparatus is less than I_{max}
 C_i plus capacitance of interconnecting cabling is less than C_a of the associated apparatus
 L_i plus inductance of interconnecting cabling is less than L_a of the associated apparatus
- 5 "Simple Apparatus" is a device that will not generate or store more than 1.2V, 0.1A, 25mW or 20uJ
- 6 In Div 2 the circuit connected to the switch may be alternatively be Non-incendive in accordance with NFPA70 Art 500-4(f)(1)

Hoffman Enclosures, Inc.

2100 Hoffman Way
Anoka, Minnesota 55303-1745 USA
Phone: 763 422-2211

P/N 89108869 Dwg 89109561 A



RSPSupply - 1-888-532-2706 - <https://www.RSPSupply.com>
See the product details here